

# MOPVC 双承口渐缩管

Mopvc Socket Reduced Tapper

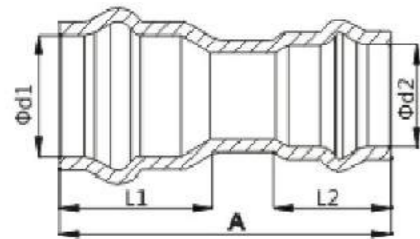

## 技术参数 SPECIFICATION

1. 测试标准/Type Test : EN14525/BS8561
2. 橡胶标准/Elastomeric : EN681-2
3. 球墨铸铁/Ductile Iron : EN1563 EN-GJS-450-10
4. 涂层标准/Coating : WIS4-52-01
5. PVC管用管件标准/Standard : En12842

## 材质 MATERIALS

序号 ITEM	部件名称 PARTS	材质 MATERIAL
1	本体/Body	球墨铸铁/Ductile iron
2	密封圈/Seals	EPDM/NBR
3	涂层/Coating	环氧树脂粉末/Fusion Bonded Epoxy

规格DIMENSIONS(PN16)						
SIZE	$\Phi d1$	$\Phi d2$	A	L1	L2	P/kg
63/50	63	50	190	95	90	1.7
75/63	75	63	200	100	95	3.2
90/63	90	63	215	105	95	3.4
90/75	90	75	215	105	100	4
110/63	110	63	235	115	95	4.2
110/75	110	75	235	115	100	4.5
110/90	110	90	240	115	105	5.5
125/63	125	63	280	125	95	3.8
125/90	125	90	260	125	105	6.5
125/110	125	110	265	125	115	7
140/90	140	90	275	130	105	5.5
140/110	140	110	270	130	115	7.3
140/125	140	125	275	130	125	8.5
160/63	160	63	285	145	95	8.5
160/75	160	75	285	145	100	8.7
160/90	160	90	285	145	105	8.9
160/110	160	110	285	145	115	9.3
160/125	160	125	285	145	125	9.5
160/140	160	140	290	145	130	10.6
200/90	200	90	310	155	105	10.4
200/110	200	110	330	155	115	13.5
200/140	200	140	330	155	130	14
200/160	200	160	340	155	145	14.5

规格DIMENSIONS(PN16)						
SIZE	$\Phi d1$	$\Phi d2$	A	L1	L2	P/kg
225/90	225	90	340	155	105	14.8
225/110	225	110	345	155	115	15.5
225/140	225	140	325	155	130	16
225/160	225	160	340	155	145	17
225/200	225	200	350	155	155	17.2
250/110	250	110	360	175	115	17
250/140	250	140	360	170	135	14
250/160	250	160	380	175	145	19.2
250/200	250	200	380	175	155	20
250/225	250	225	400	175	155	22
280/160	280	160	400	185	145	24
280/225	280	225	400	185	155	26
280/250	280	250	420	185	175	27.7
315/110	315	110	410	190	155	24
315/160	315	160	420	190	155	29
315/200	315	200	430	190	155	27.5
315/225	315	225	400	190	155	30.5
315/250	315	250	435	190	175	30
355/250	355	250	430	205	175	33
355/315	355	315	450	205	190	33.2
400/250	400	250	480	230	175	40.3
400/315	400	315	480	230	190	42.5
400/355	400	355	500	230	205	46

# 球墨铸铁11.25°双盘弯管

Ductile Iron Double Flange Bend - 11.25°

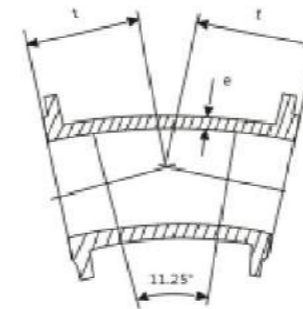

## 技术参数 SPECIFICATION

1. 测试标准/Type Test : EN14525/BS8561
2. 橡胶标准/Elastomeric : EN681-2
3. 球墨铸铁/Ductile Iron : EN1563 EN-GJS-450-10
4. 涂层标准/Coating : WIS4-52-01
5. 球墨铸铁管用管件标准/Standard : EN545/ISO2531
6. 钻孔标准/Drilling Spec : EN1092-2

## 材质 MATERIALS

序号 ITEM	部件名称 PARTS	材质 MATERIAL
1	本体/Body	球墨铸铁/Ductile iron
2	密封圈/Seals	EPDM/NBR

## 规格DIMENSIONS(PN16)

DN	E	T	重量Mass		
			PN10	PN16	PN25
80	7	130	9.5	9.5	9.5
100	7.2	140	11.5	11.5	12.5
150	7.8	160	19.1	19.1	21
200	8.4	180	29.9	29	32
250	9	350	55.9	56	64
300	9.6	400	79.3	79	90
350	10.2	298	79	84	100.4
400	10.8	324	100	109	131
450	11.4	349	123	139	166
500	12	375	152	179	201
600	13.2	426	222	269	299
700	14.4	478	313	336	
800	15.6	529	426	455	
900	16.8	581	546	584	
1000	18	632	704	773	
1100	19.2	683	882	952	
1200	20.4	735	1094	1204	
1400	22.8	835	1560	1674	
1500	24	885	1849	2025	
1600	25.2	940	2203	2382	
1800	27.6	345	1258	1566	
2000	30	375	1694	1970	